

REV	DESCRIPTION	DESIGN	DATE
AO	Release	吴丹平	2016.04.30

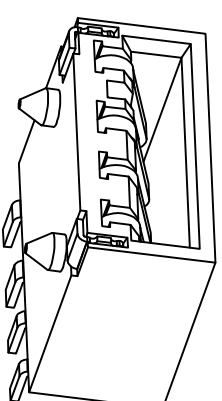

**主要技术参数 Main Specifications**

板厚 (thickness): 1.0mm

接触电阻 (Contact resistance):  $\leq 20m\Omega$

绝缘电阻 (Insulation resistance):  $\geq 800M\Omega$

额定电压 (Rated voltage): 250/150V AC DC

额定电流 (Rated current): 1.0A AC DC

耐电压 (Withstand Voltage): 1500V AC/minute

温度范围 (Temperature Range):  $-25^{\circ}C \sim +105^{\circ}C$

Board Layout

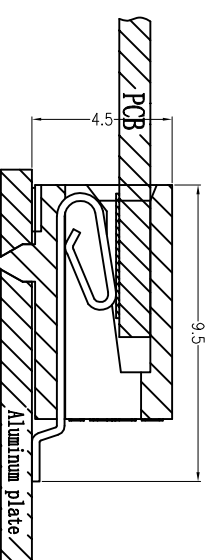
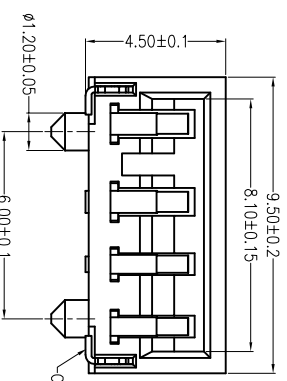
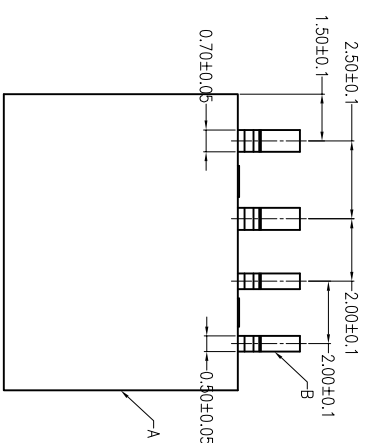
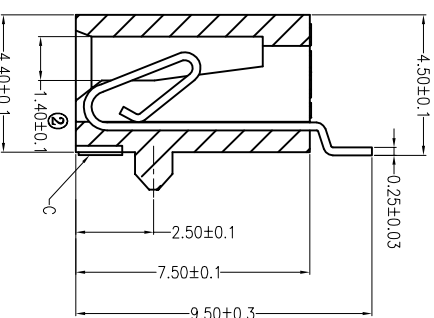
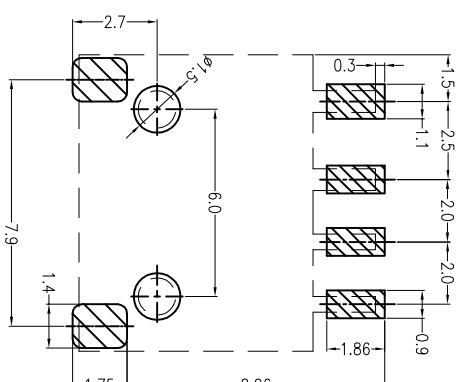

Assembly Layout

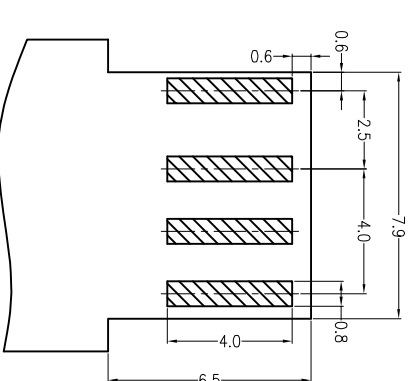

Mating Aluminum plate detail

ORDER INFORMATION:

PART No. **L022-04-F2MB-R**

No. OF CIRCUITS: 04

PLASTIC MATERIAL: F2M=LCP (BEIGE)

PACKAGING: R=REEL, P=PE, PLATING: B=MATTE Sn

ITEM	COMPONENT	QTY	MATERIAL	FINISH
C	Solder Tab	2 PCS	PhosphorBronze	MATTE Sn-plated
B	CONTACT	4 PCS	PhosphorBronze	MATTE Sn-plated
A	PEDESTAL	1 PCS	LCP	UL 94V-0, COLOR:BEIGE

**JKUN 温州健坤连接器有限公司**  
**WENZHOU JKUN CONNECTOR CO., LTD.**

TITLE: -  
 2.5/2.0mmPITCH 90WAFER SMT TYPE

X:±0.5	X:±5°	USE: CUSTOMER	PART NO.:	L022-04-F2MB-R
X±0.3	X±2°	APPD: 邵敬和	DWG NO.:	JKUN/GCCP-0080
.XX±0.25	.XX±1°	CHKD: 田峰	SCALE	1 : 1
--	--	DR: 周秀龙	SHEET	1 / 1